

ASCEND ACCESS SYSTEM & SCAFFOLDING

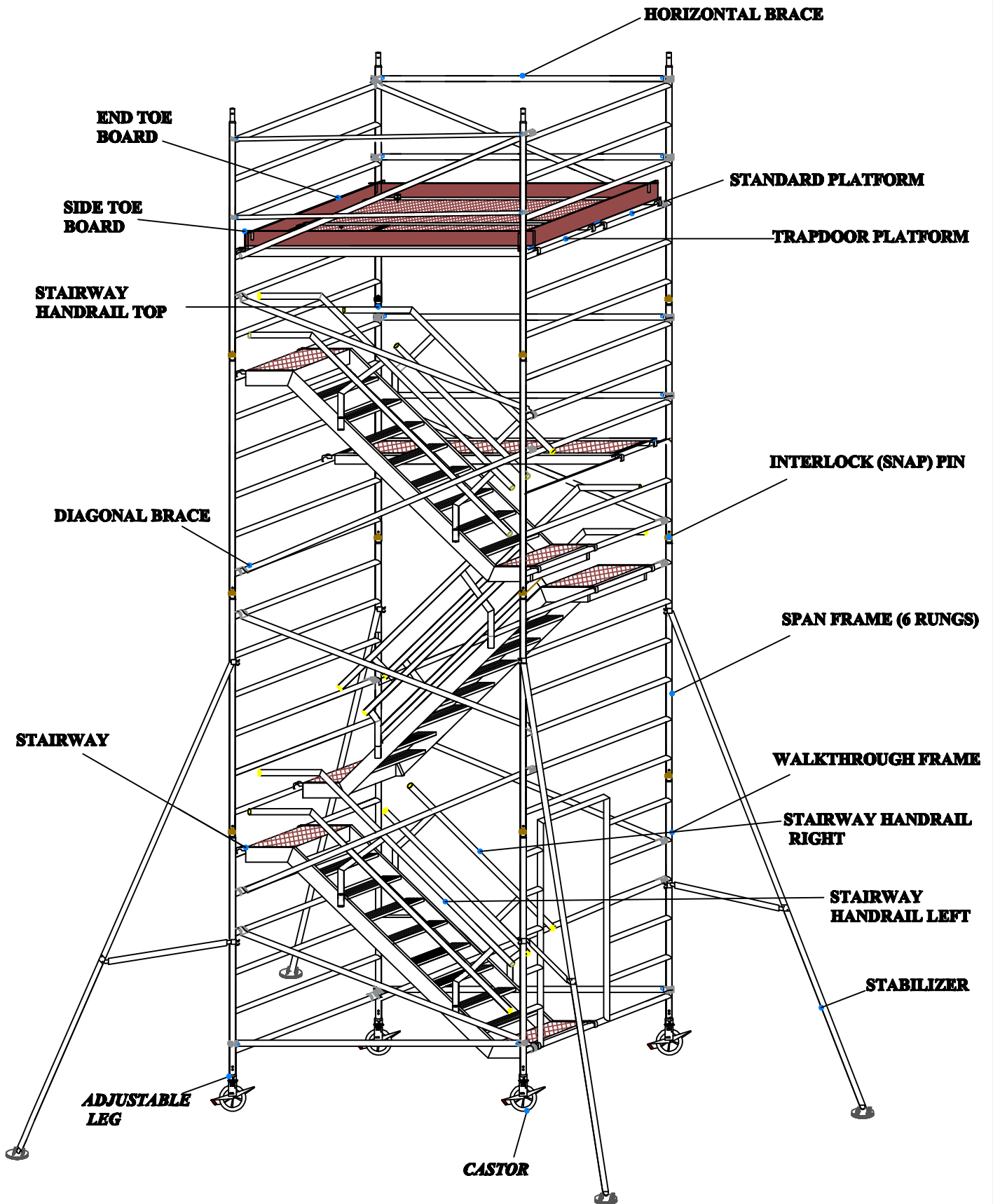

KM 697336

ASCEND STAIRWAY WITH 3T METHOD



STEP 1:

- ☛ Insert adjustable leg /caster into the the 6 rungs span and walk through frame. Apply brake by pusing the lever down, adjustable legs should only be used for leveling .

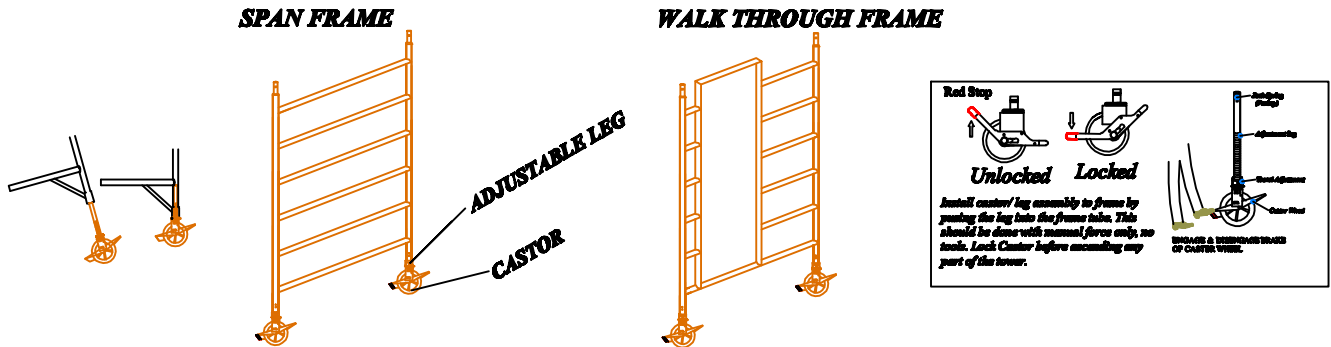

Caster may be unlocked when you are moving the tower

STEP 2:

- ☛ Fit two horizontal braces, **BLUE** colour coded to the vertical member of the frame as low as possible. both barce hook line must face from inside towards outside. Check the brace is correctly locked on the frame at the both ends.

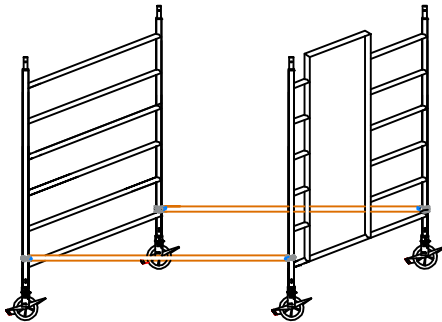

STEP 3:

- ☛ Fit two diagonal braces, **YELLOW** colour coded. diagonal brace between the 1st and 4th rungs of the tower, as show below. check the base unit is squire and level using spirit level. Adjustable legs only to level and not gain to extra height

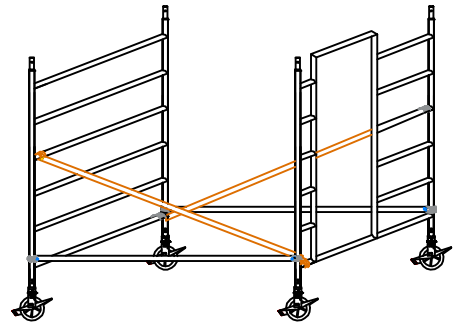

STEP 4:

- ☛ Fit the stairway unit between 1st rungs of walk throught frame and 6th rungs of the span frame.

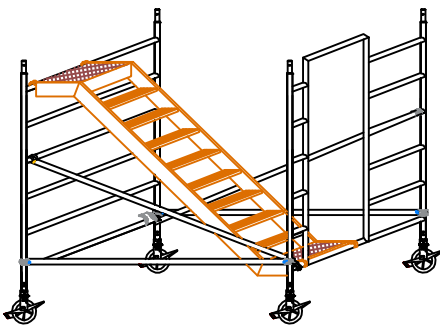

STEP 5:

- ☛ Fit the right and left stairway handrail.
- ☛ Fit a temporary standard platform on the 3rd rungs.
- ☛ Fit guardrail (horizontal brace) on the 4th and 6th rungs, near the platform

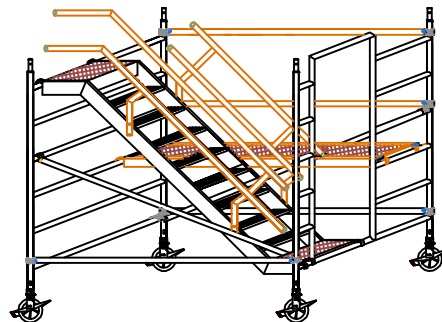

STEP 6:

- ☛ Standing on the platform fit 6 rungs frame additional two sides, on the lower frames.
- ☛ Ensure the frame interlock (snap) pin engaged.

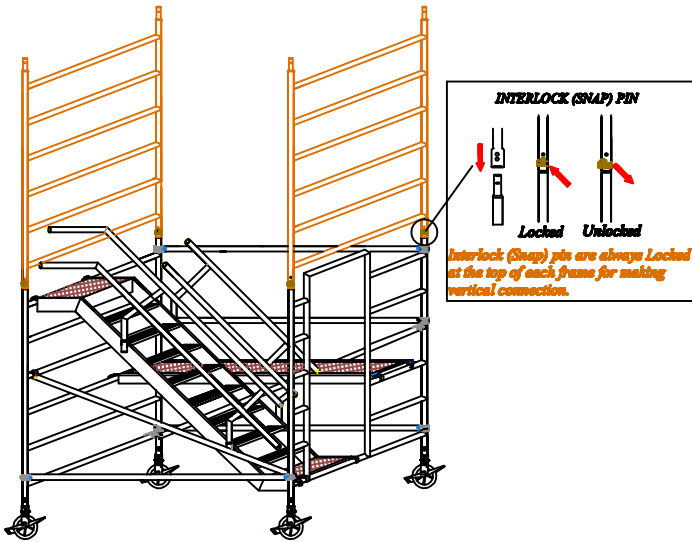

STEP 7:

- ☛ Fit next pair of diagonal braces, **YELLOW** colour coded, diagonal brace between the 5th to 8th and 9th to 12th rungs of the tower on both the sides of the frames, as show below.

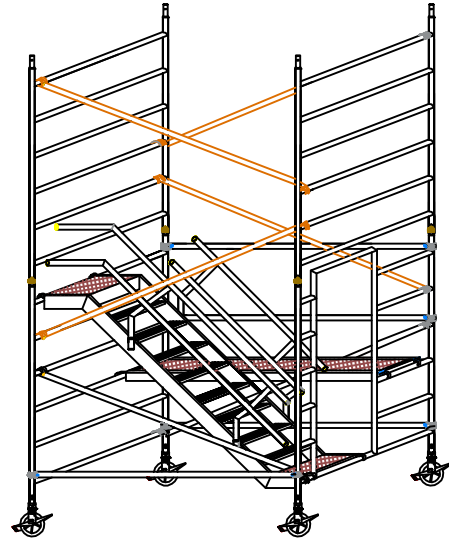

STEP 8:

- ☛ Fit the stairway unit between 7th rungs and 12th rungs of the span frame.
- ☛ Fit the right & left stairway handrail

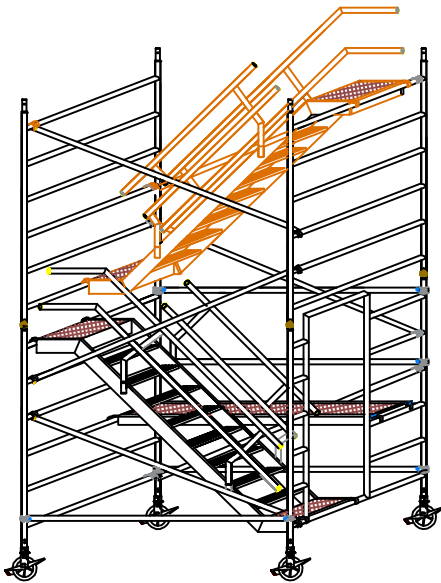

STEP 9:

- ☛ Remove the temporary platform & guardrail from 3rd rungs and fit on the 9th rungs
- ☛ Fit guardrail (horizontal brace) on the 10th and 12th rungs near the platform.
- ☛ Fit a (4.5 m) stabilizer span frame at either end of the tower.

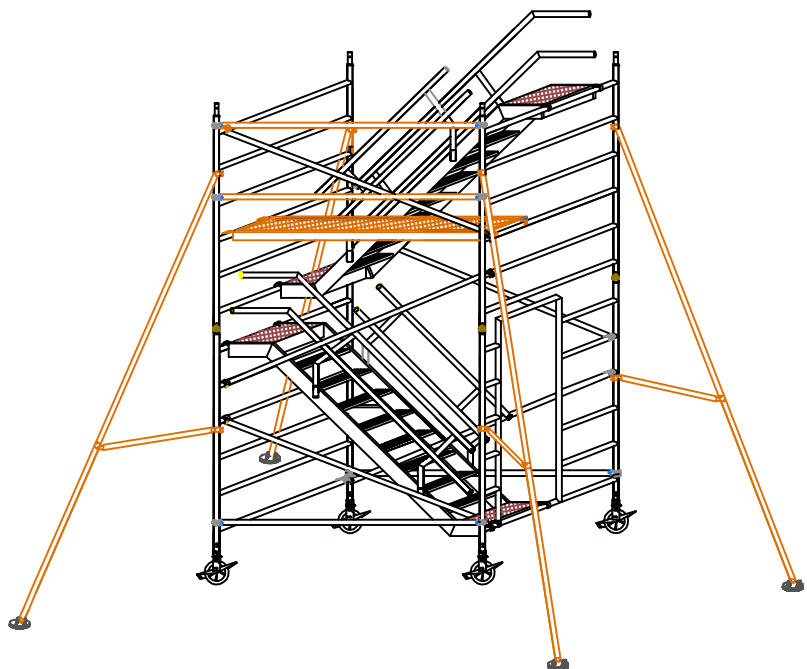

STEP 10:

- ☛ *Standing on the platform add two more 6 rungs frame additional two sides, on the lower frames.*
- ☛ *Ensure the frame interlock (snap) pin engaged.*
- ☛ *Add two more next pair diagonal braces, **YELLOW** colour coded. diagonal brace between the 13th to 16th rungs of the tower on both the sides of the frame, as show below.*

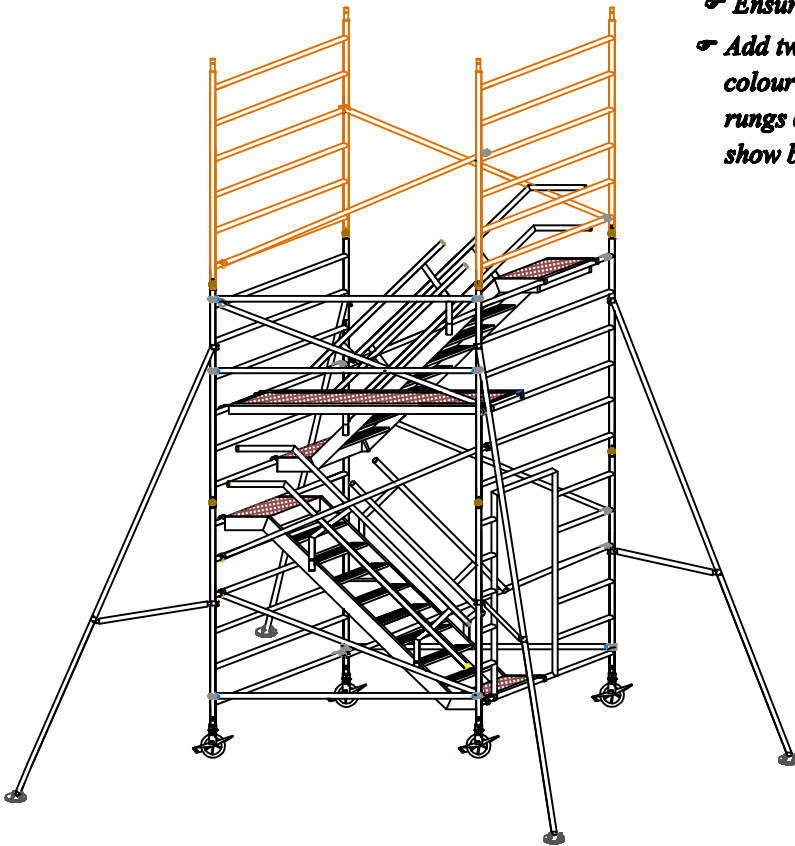

STEP 11:

- ☛ *Remove the temporary platform & guardrail from 9th rungs fit on 15th rungs, fit guardrail (horizontal brace) on the 16th and 18th rungs near the platform.*

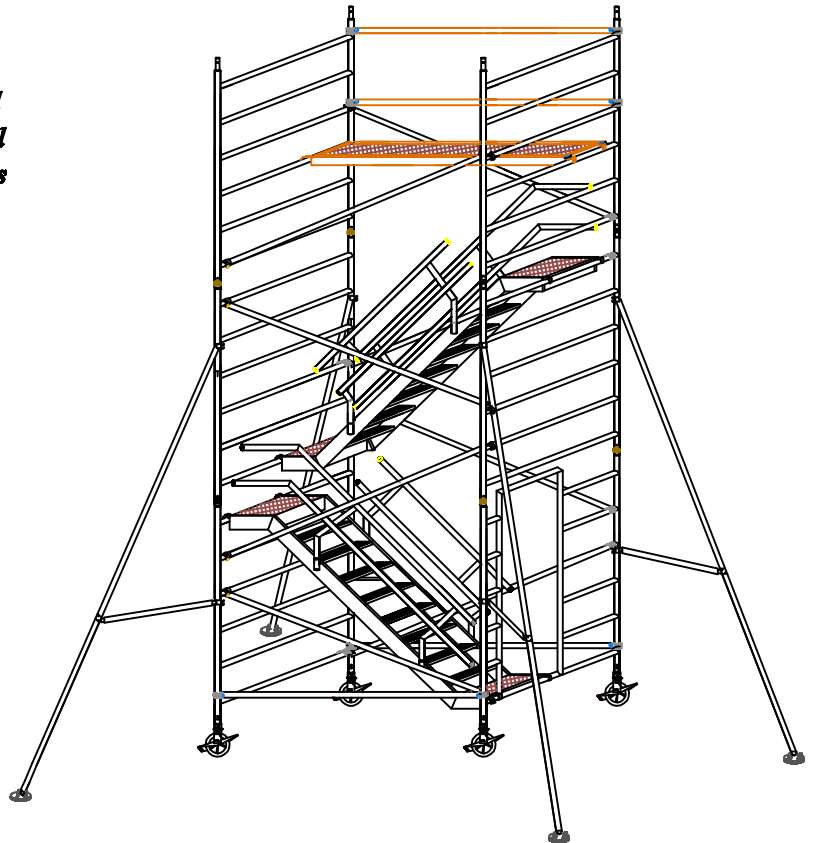

STEP 12:

- ☛ *Fit the next stairway unit between 13th rungs and 18th rungs of the span frame*
- ☛ *Fit the next left and top stairway handrail*

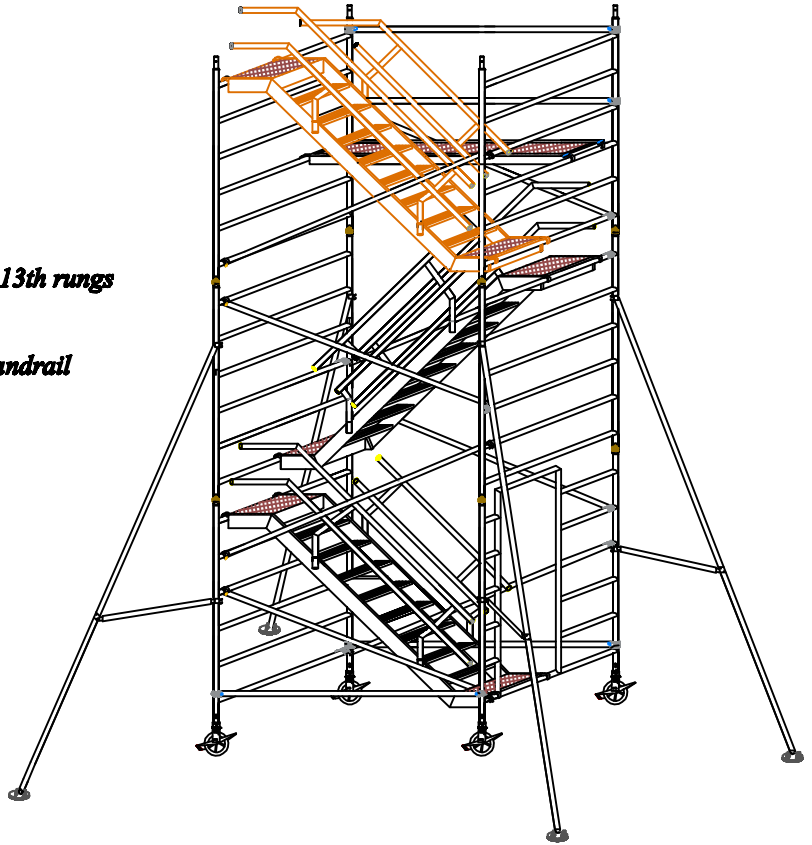

STEP 13:

- ☛ *Standing on the platform fit 6 rungs frame additional two sides, on the lower frames.*
- ☛ *Ensure the frame interlock (snap) pin engaged.*
- ☛ *Add two more next pair diagonal braces, **YELLOW** colour coded. diagonal brace between the 17th to 20th and 21th to 24th rungs of the tower on each side of the tower frame, as show drawing.*

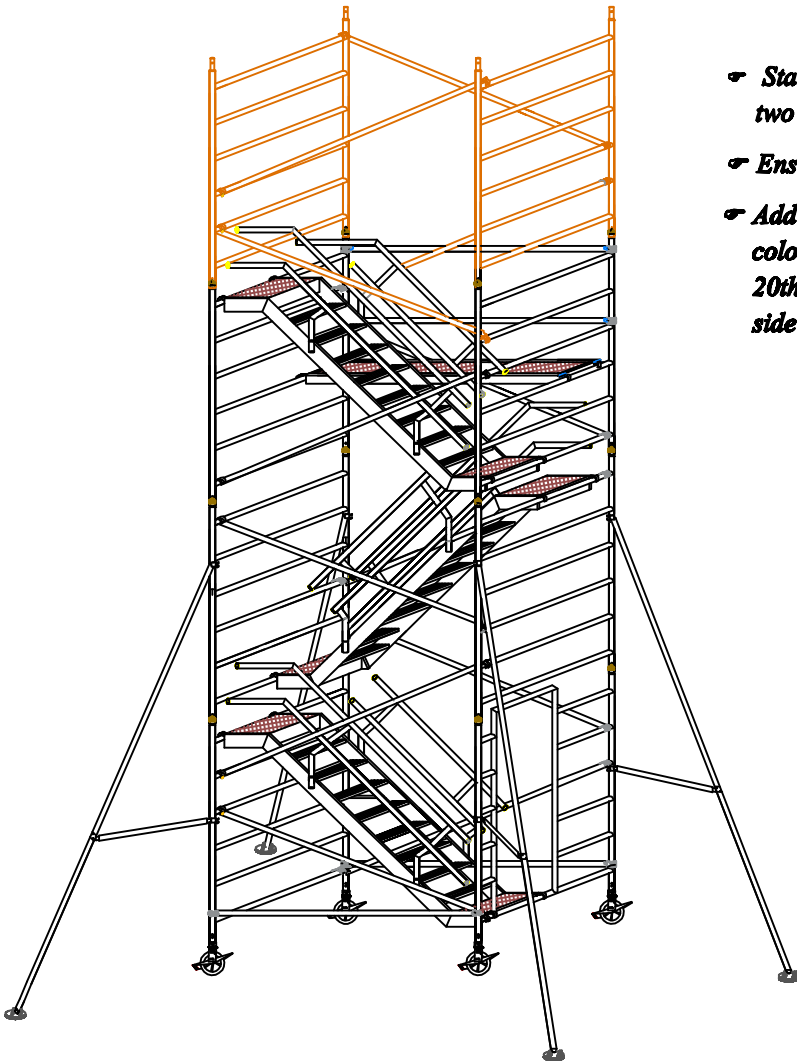

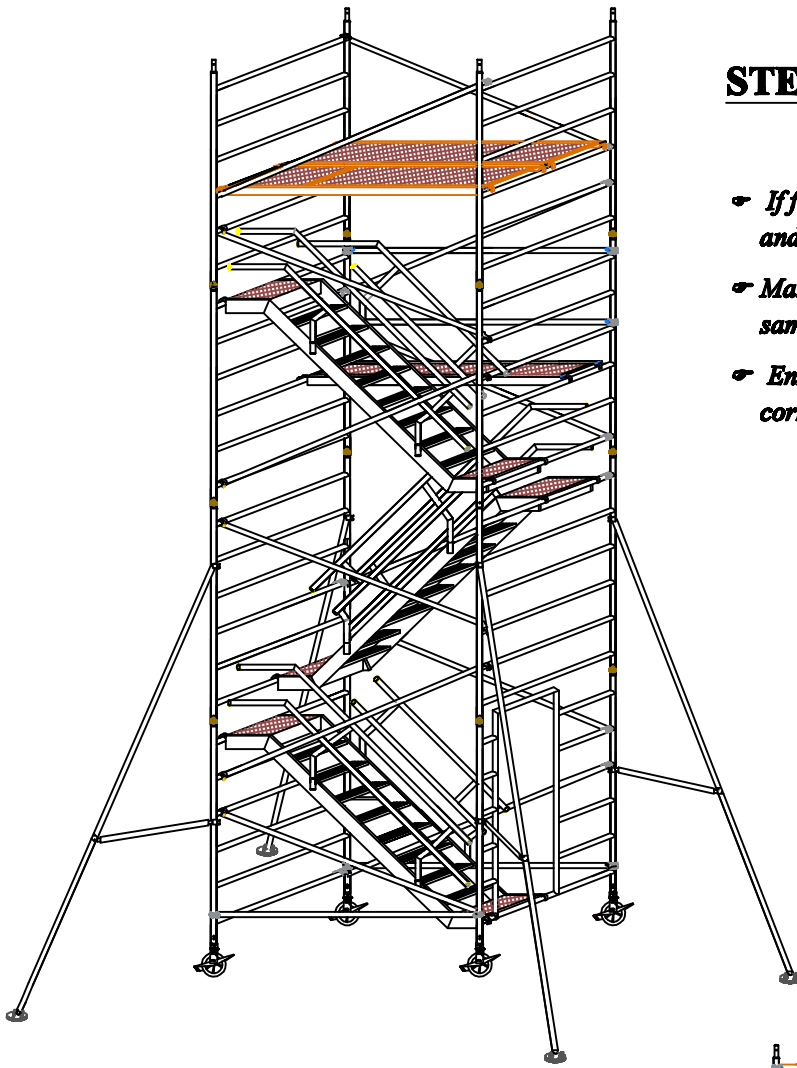

STEP 14:

- *If finishing at this height (7.3 platform) fix standard and trapdoor platform on the 4th rungs from the top.*
- *Make sure trapdoor platform door opens on the same side of stairway.*
- *Ensure wind lock system of the platform are in the correct locked position.*

STEP 15:

- *Fit (guardrail) two horizontal brace on both sides of the platform on 1st & 3rd rungs from the top . as show drawing*

